

Productblad

FT1105 | Workout en Fitness

FT1105

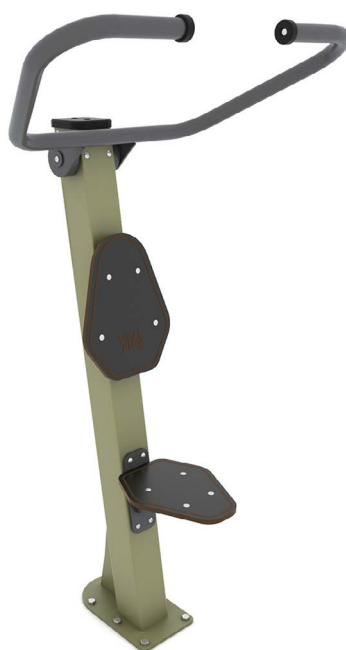

Productomschrijving

De Shoulder Press is een ideaal product om o.a. de schouders mee te trainen. Met onze outdoor Fitness producten creeër je een actie workout voor de buitenruimte.

Opties

Beschikbaar in kleur(en): Grijs, Lime, Mos, Paars, Turquoise





FT1105 | Workout en Fitness

FT1105

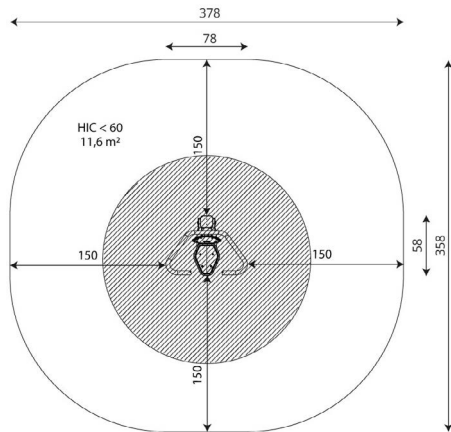

plattegrond

Toestelspecificaties

Afmetingen toestel	0,8 x 0,6 m
Opvangzone	13,6 m ²
Totaal hoogte	1,6 m
Valhoogte	0,6 m

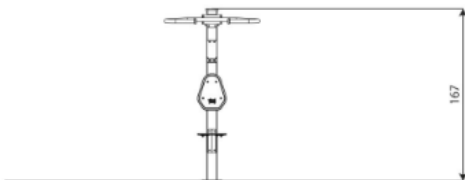

zij aanzicht

Materialen

Constructie	Staal
-------------	-------

Let op: valdemping vereist

