

Productblad

FT1107 | Workout en Fitness

FT1107



Productomschrijving

Train je heupen en core met de Hip Swing. Met onze outdoor Fitness producten creëer je een actie workout voor de buitenruimte. Train kracht, lenigheid, snelheid, coördinatie en uithoudingsvermogen in een opbouwend circuit

Opties

Beschikbaar in kleur(en): Grijs, Lime, Mos, Paars, Turquoise





FT1107 | Workout en Fitness FT1107

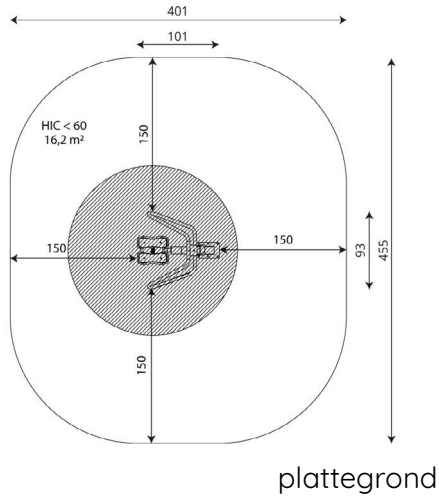

Toestelspecificaties

Afmetingen toestel	1,0 x 1,0 m
Opvangzone	18,1 m ²
Totaal hoogte	1,5 m
Valhoogte	0,6 m

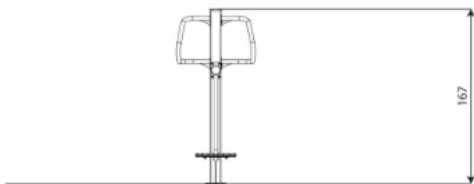

zij aanzicht

Materialen

Constructie	Staal
-------------	-------

Let op: valdemping vereist

