

Productblad

RB2302 | Workout en fitness

RB2302



Productomschrijving

De brug of 'Parallel bars' is speciaal om dips te oefenen. Steun met je armen op de stangen en werk met je lichaamsgewicht. Door dips te oefenen worden de borst-, schouder- en armspieren getraind. Outdoor trainen is in opmars en daarvoor zijn meestal geen geavanceerde sporttoestellen nodig

Opties

Beschikbaar in kleur(en): Houtlook





RB2302 | Workout en fitness RB2302

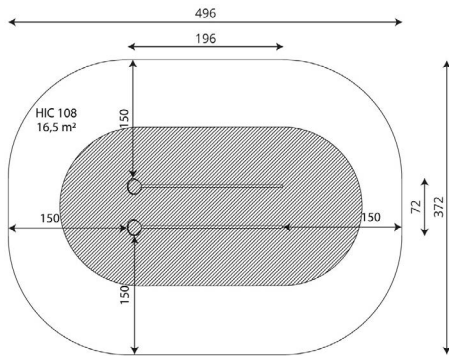

plattegrond

Toestelspecificaties

Afmetingen toestel	2,0 x 0,7 m
Opvangzone	18,0 m ²
Totaal hoogte	1,2 m
Valhoogte	1,1 m

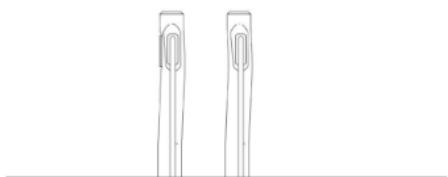

zijaanzicht

Materialen

Constructie	Robinia
Slangen	RVS

Let op: valdemping vereist

