

# Productblad

RB2314 | Workout en Fitness

RB2314



## Productomschrijving

De Overhead ladder of Monkey bar is ideaal om de armspieren te trainen. Klim van begin tot eind zonder dat je voeten de vloer raken. Natuurlijk past deze perfect in een obstacle course.

## Opties

Beschikbaar in kleur(en): Houtlook





## RB2314 | Workout en Fitness

RB2314

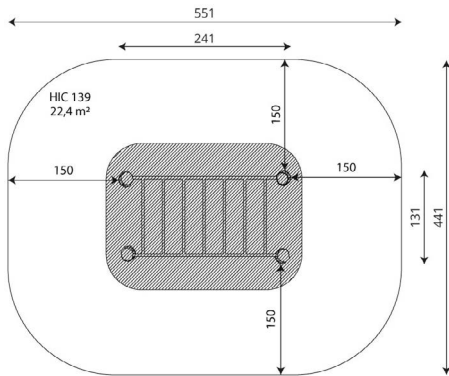

plattegrond

### Toestelspecificaties

Afmetingen toestel	2,3 x 1,2 m
Opvangzone	22,3 m <sup>2</sup>
Totaal hoogte	2,5 m
Valhoogte	1,4 m

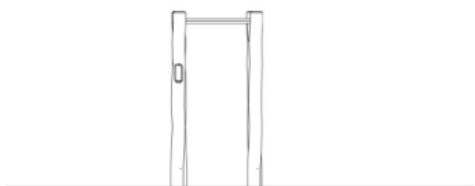
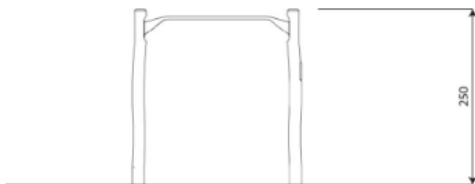

zijaanzicht

### Materialen

Constructie	Robinia
Stangen	RVS

Let op: valdemping vereist

