



Productblad

WO2302 | Workout & Fitness

WO2302



Productomschrijving

De brug of 'Parallel bars' is speciaal om dips te oefenen. Steun met je armen op de stangen en werk met je lichaamsgewicht. Door dips te oefenen worden de borst-, schouder- en armspieren getraind.

Opties

Beschikbaar in kleur(en): Grijs, Lime, Mos, Paars, Turquoise





WO2302 | Workout & Fitness

WO2302

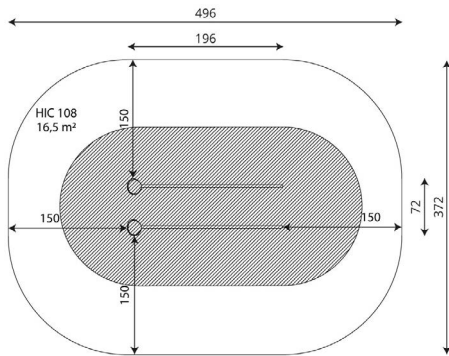

plattegrond

Toestelspecificaties

Afmetingen toestel	2,0 x 0,7 m
Opvangzone	18,0 m ²
Totaal hoogte	1,2 m
Valhoogte	1,1 m

Materialen

Constructie	Robinia
Stangen	RVS

zijaanzicht

Let op: valdemping vereist

