



Productblad

WO2314 | Workout & Fitness

WO2314



Productomschrijving

De Overhead ladder of Monkey bar is ideaal om de armspieren te trainen. Klim van begin tot eind zonder dat je voeten de vloer raken. Natuurlijk past deze perfect in een obstacle course.

Opties

Beschikbaar in kleur(en): Grijs, Lime, Mos, Paars, Turquoise





WO2314 | Workout & Fitness WO2314

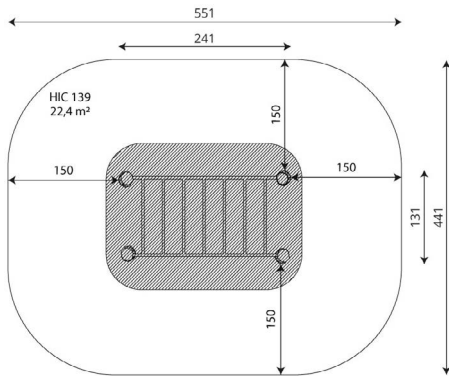

plattegrond

Toestelspecificaties

Afmetingen toestel	2,3 x 1,2 m
Opvangzone	22,3 m ²
Totaal hoogte	2,5 m
Valhoogte	1,4 m

Materialen

Constructie	Robinia
Stangen	RVS

zijaanzicht

Let op: valdemping vereist

